

Isothermal Vapor–Liquid Equilibrium Data for Tetrafluoromethane + Ethane over a Temperature Range from (179.68 to 210.03) K

Hongbo Zhu,^{†,‡} Maoqiong Gong,^{*,†} Yu Zhang,^{†,‡} and Jianfeng Wu[†]

Technical Institute of Physics and Chemistry, Chinese Academy of Sciences, P.O. Box 2711, Beijing 100080, China, and Graduate School of the Chinese Academy of Sciences, Beijing 100039, China

Isothermal vapor–liquid equilibrium (VLE) data for {tetrafluoromethane (R14) + ethane (R170)} were measured at (179.68, 190.14, 200.68, and 210.03) K. A recirculation-method apparatus was used in this measurement, in which a self-made electromagnetic recirculation pump was used to drive the vapor to accelerate the thermodynamic equilibrium process. The measured VLE data were fitted with the Peng–Robinson equation and the Huron–Vidal mixing rule. The calculated results were compared with the experimental data.

Introduction

In recent years, there have been some great achievements in the research of low-temperature mixed-gases Joule–Thomson refrigerators (MJTRs).^{1–5} By using optimal compositions of refrigerant mixtures, the thermodynamic efficiency of the Joule–Thomson refrigerator has been greatly improved. Driven by a single-stage oil-lubricated commercial compressor, this refrigerator has especially become dominant for applications over a large temperature range from (78 to 233) K due to its numerous merits, such as no moving parts at low temperatures, high reliability, high thermodynamic performance, low cost, etc. However, there are still many important and difficult problems on MJTRs to be investigated. One important problem is the accurate prediction of the thermodynamic properties of multi-component mixtures, especially in two-phase regions. VLE data are one of the most important and fundamental properties in the study of the MJTRs.

In a typical MJTR, usually more than five or six, even seven, components are used to obtain the multicomponent mixed-refrigerant according to different refrigeration temperatures. These components are usually selected from inert gases (such as nitrogen, argon, and neon), natural gas components (e.g., methane, ethane, and propane), and some synthetic components {e.g., tetrafluoromethane (R14), trifluoromethane (R23), and 1,1,2,2,3,3,4,4-octafluorobutane (R318)}.^{4,5} It is true that lots of important data (e.g., the binary interaction parameters used for the prediction of the thermodynamic properties of the multicomponent mixtures) are not available from the open published literature.

To get those fundamental data, especially the VLE data for those components, an experimental rig was developed to measure the VLE data of those components of interest.^{6,7} In this paper, the VLE data of {tetrafluoromethane (R14) + ethane (R170)} were measured over a temperature range from (179.68 to 210.03) K. The measured VLE data were fitted with the Peng–Robinson equation of state. In addition, tetrafluoromethane and ethane are both ozone-friendly materials and have no ozone depletion potential (ODP) values. Ethane (R170) has

Table 1. Ozone Depletion Potential (ODP) and Global Warming Potential (GWP) for Tetrafluoromethane and Ethane

serial no. of refrigerants	molecule formula	chemical name	ODP ⁸	GWP ⁸
R14	CF ₄	tetrafluoromethane	0.0	5700
R170	C ₂ H ₆	ethane	0.0	about 20

an extremely small global warming potential (GWP) value, while tetrafluoromethane (R14) has a larger one. Both ODP and GWP values for tetrafluoromethane and ethane are listed in Table 1.

Experimental Section

Materials. Tetrafluoromethane was supplied by Special Chemical Product Inc. (USA) with a molar fraction purity of > 99.97 %. Ethane was supplied by Airgas Inc. (USA) with a molar fraction purity of > 99.95 %. Both materials were used without further purification.

Apparatus. A vapor phase recirculation apparatus was designed for the isothermal VLE measurements. Details of this apparatus have been reported previously and already used to get reliable azeotropic points of the binary azeotropic mixtures.^{6,7}

The electromagnetic pump is crucial in the whole recirculation apparatus. The structure is shown in Figure 1. With the interaction of the electromagnetic force and the spring force, the piston inside the electromagnetic recirculation pump was in reciprocal motion in the cylinder. The electromagnetic recirculation pump sucked when the piston moved to the upstroke and discharged when the piston moved to the downstroke, coupled with the on–off of the check valves, which resulted in a continuous one-way flow of the vapor inside the pump.

According to the recirculation method, the vapor phase was taken out from the top of the equilibrium cell and driven to circulate by the electromagnetic pump with a volume flow rate ranging from (3 to 10) cm³/s and then mixed with the liquid phase at the cell bottom after passing a counter-current heat exchanger and the precooling coils, which were immersed in the liquid bath. The stainless steel equilibrium cell with a volume of 300 cm³ was immersed in a thermostatic liquid bath filled with dichlorodifluoromethane (R12). The liquid bath was cooled by liquid nitrogen coils and heated with an electric heater. The

* Corresponding author. E-mail: gongmq71@hotmail.com. Tel: +86 10 62578910. Fax: +86 10 62627843.

[†] Technical Institute of Physics and Chemistry, Chinese Academy of Science.

[‡] Graduate School of the Chinese Academy of Sciences.

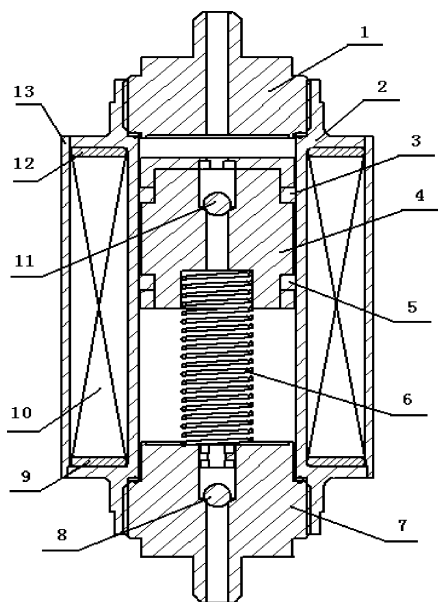

Figure 1. Cross section of the self-made electromagnetic recirculation pump: 1, upper closure; 2, cylinder; 3, upper gasket of the piston; 4, free-fitting piston; 5, bottom gasket of the piston; 6, restoring spring; 7, bottom closure; 8, bottom check valve; 9, bottom iron gasket; 10, solenoids; 11, upper check valve; 12, upper iron gasket; 13, sleeve.

temperature fluctuation in the liquid bath was controlled within ± 0.01 K.

The temperature of the thermostatic liquid bath was controlled by a Shimaden SR253 digital controller. A requested uniform temperature distribution was obtained with an electromagnetic stirrer fixed at the liquid bath bottom. The temperature in the equilibrium cell was measured by a standard platinum resistance thermometer with a nominal resistance of 25Ω and calibrated by the Cryogenic Metrology Station of the Chinese Academy of Sciences. The uncertainty was estimated to be ± 0.01 K.

The pressure in the equilibrium cell was measured with a pressure transducer {Druck; type PMP4010; range (0 to 6) MPa}. The uncertainty was estimated to be ± 0.002 MPa, after a careful calibration with a dead weight piston pressure tester {Fourth Automation Instrument plant; model YU60; range (0.1 to 6) MPa, Shanghai, China} before measurement.

The composition measurement was performed using a gas phase chromatograph (Beifen model SP3400) equipped with a thermal conductivity detector (TCD). The signal generated by the detector is sent to the workstation (BF9202, Beijing, China, an auxiliary of the GC3400). The column used in the GC is HDG-202A 60/80 mesh (stainless steel tube; length, 6 m; o.d., 3 mm; i.d., 2 mm; from Beifen). The normalizing peak area method was used to determine the composition. A composition known reference mixture that was made based on mass basis was used to calibrated the GC, in which a precise balance (Sartorius BS 4000S) was used to get the reference mixture. The uncertainty of mass measurement with the Sartorius BS 4000S precision balance is 0.01 g. After careful calibration, the correcting factor for the peak area normalization method was obtained, and the uncertainty of the composition was estimated to be ± 0.001 in mole fraction over the whole range of concentrations. Of course, different analytical columns have different uncertainties of the same mixtures. The detailed verification and description of the whole experimental apparatus had been presented elsewhere.⁹

Experimental Process. At room temperature, the equilibrium cell and loading circuit were first evacuated. When the thermostatic bath was cooled, a certain amount of ethane (the

Table 2. Critical Parameters and Acentric Factors¹⁰ for Tetrafluoromethane and Ethane

compound	T_C /K	P_C /MPa	ω
ethane	305.45	4.884	0.099
tetrafluoromethane	227.60	3.739	0.191

higher boiling temperature component) was charged in the equilibrium cell from the feed cylinder. After the required equilibrium temperature was reached and the fluctuation was controlled within the desired uncertainty for about 10 min, the vapor pressure was recorded at this temperature. To get the two-phase envelope, at least 8 PT_{xy} data points at the same temperature are needed. So different amounts of tetrafluoromethane (the low boiling temperature component) were charged step by step from the feed cylinder to make the required composition. Equilibrium state was assumed to be reached when the total pressure remained unchanged within ± 0.002 MPa for at least 10 min at the required temperature.

For each equilibrium state, at least four samples of both vapor and liquid phases were withdrawn and analyzed by the gas chromatograph, and the average value was recorded. Changing the required temperatures and repeating the process above, other PT_{xy} data could be obtained.

Correlations

In this paper, the isothermal experimental PT_{xy} data of {tetrafluoromethane (R14) + ethane (R170)} were measured at four temperatures (179.68, 190.14, 200.68, and 210.03) K. The critical temperature (T_C), critical pressure (P_C), and acentric factor (ω) for each pure component were all obtained from a commercial software of ProII¹⁰ and are shown in Table 2. The correlation was conducted with ProII. The original Peng–Robinson¹¹ equation of state (PR EOS) shows good calculated results for either nonpolar or slightly polar mixtures. The Huron–Vidal¹² mixing rule presents good correlation to binary mixtures with one or two polar compounds and is also good for nonpolar mixtures. Therefore, the PR EOS with the Huron–Vidal mixing rule was used to correlate the measured data in this work.

In the correlations, the objective function of regression was from ProII and had such a form as

$$F = \sum_{i=1}^N \left(\sum_{j=1}^{\text{NOC}} \left(1.0 - \frac{y_{ij\text{cal}}}{y_{ij\text{exp}}} \right)^2 + \left(1.0 - \frac{P_{i\text{cal}}}{P_{i\text{exp}}} \right)^2 \right) \quad (1)$$

where N is the number of data points, $P_{i\text{exp}}$ is the measured pressure, and $P_{i\text{cal}}$ is the calculated pressure. NOC is the number of components. $y_{ij\text{exp}}$ is the measured vapor mole fraction, and $y_{ij\text{cal}}$ is the calculated vapor mole fraction.

The Huron–Vidal mixing rule was used in this work, where the attractive parameter was calculated from eq 2 and the molar co-volume was from eq 3:

$$a = b \sum_{i=1}^n x_i \left(\frac{a_i}{b_i} - \frac{1}{\ln 2} \frac{\sum_{j=1}^n x_j G_{ji} C_{ji}}{\sum_{k=1}^n x_k G_{ki}} \right) \quad (2)$$

$$b = \sum_{i=1}^n x_i b_i \quad (3)$$

where C_{ji} is an adjustable parameter. G_{ji} is calculated with C_{ji}

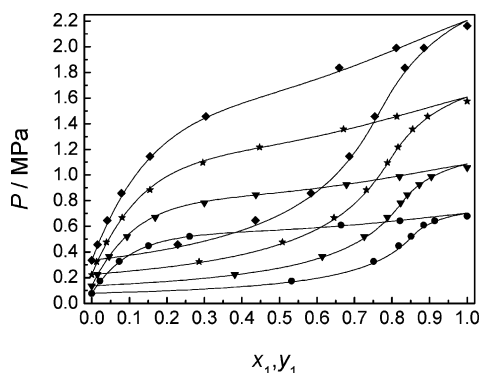

Figure 2. Vapor–liquid equilibrium data for {tetrafluoromethane (1) + ethane (2)} at four different temperatures: ●, 179.68 K; ▼, 190.14 K; ★, 200.68 K; ◆, 210.03 K; —, calculated with the PR equation and the Huron–Vidal mixing rule.

Table 3. Interaction Parameters of the Huron–Vidal Mixing Rule with PR Equation for {Tetrafluoromethane (1) + Ethane (2)}

T/K	C_{12}	C_{21}	α_{12}
179.68	1471.84	2341.60	0.32
190.14	1229.50	2418.66	0.27
200.68	976.18	2452.00	0.22
210.03	744.92	2449.73	0.18

from eq 4:

$$G_{ji} = b_j \exp\left(-\alpha_{ji} \frac{C_{ji}}{RT}\right) \quad (4)$$

where α_{ji} is another adjustable parameter, and $\alpha_{ji} = \alpha_{ij}$, but C_{ij} is not equal to C_{ji} . They are all adjusted directly to VLE data using the objective function described in eq 1.

Results and Discussion

The measured VLE data and calculation results correlated with the PR–HV model were shown in Figure 2. At each temperature, the three parameters C_{ij} , C_{ji} , and α_{ji} , adjusted as functions of temperature, have the following forms as

$$C_{ij}/\text{J}\cdot\text{mol}^{-1} = [-3.78043 + 1045.24(K/T) - 33948.8(K^2/T^2)](RT/\text{J}\cdot\text{mol}^{-1}) \quad (5)$$

$$C_{ji}/\text{J}\cdot\text{mol}^{-1} = [-3.94637 + 1909.59(K/T) - 165101(K^2/T^2)](RT/\text{J}\cdot\text{mol}^{-1}) \quad (6)$$

$$\alpha_{ji} = 1.12619 - 0.00450417(T/K) \quad (7)$$

The results of these three adjustable parameters were calculated with eqs 5 to 7 and are listed in Table 3.

The results of the correlation and experiment are presented in Table 4, while the error estimate is shown in Figures 3 and 4. As seen from Table 4, the vapor pressure of pure tetrafluoromethane was not very well correlated with the PR–HV model. To get a closed phase envelope curve, the vapor pressures of pure tetrafluoromethane and ethane were compared with the values estimated from REFPROP 7.0,¹³ and the deviations are listed in Table 5. The deviations for tetrafluoromethane were much too big. To make clear whether the experimental data for pure tetrafluoromethane were accurate, the vapor pressures at four same temperatures were measured again and are listed in Table 6. The deviations of them were within the desired uncertainty of pressure, so the measured vapor pressures of pure tetrafluoromethane were validated to be accurate. To improve

Table 4. Comparison between Experimental and Calculated Data of Saturation Pressure and Vapor Phase Composition for {Tetrafluoromethane (1) + Ethane (2)}

x_1	$P_{\text{exp}}/\text{MPa}$	$P_{\text{cal}}/\text{MPa}$	$\Delta P\%^a$	$y_{1\text{exp}}$	$y_{1\text{cal}}$	Δy^b
$T = 179.68 \text{ K}$						
0.000	0.077	0.078	-1.30	0.000	0.000	0.000
0.022	0.174	0.169	2.87	0.532	0.536	-0.004
0.073	0.327	0.321	1.83	0.751	0.756	-0.005
0.151	0.447	0.447	0.00	0.818	0.827	-0.009
0.261	0.522	0.521	0.19	0.851	0.854	-0.003
0.664	0.609	0.603	0.99	0.884	0.889	-0.005
0.821	0.643	0.646	-0.47	0.914	0.922	-0.008
1.000	0.679	0.702	-3.39	1.000	1.000	0.000
$T = 190.14 \text{ K}$						
0.000	0.136	0.136	0.00	0.000	0.000	0.000
0.015	0.225	0.223	0.89	0.384	0.385	-0.004
0.046	0.366	0.364	0.55	0.614	0.620	-0.006
0.094	0.521	0.528	-1.34	0.726	0.736	-0.010
0.169	0.670	0.680	-1.49	0.788	0.796	-0.008
0.300	0.783	0.792	-1.15	0.823	0.828	-0.005
0.437	0.847	0.845	0.24	0.841	0.843	-0.002
0.679	0.926	0.929	-0.32	0.873	0.875	-0.002
0.820	0.988	0.996	-0.81	0.905	0.913	-0.008
1.000	1.058	1.086	-2.65	1.000	1.000	0.000
$T = 200.68 \text{ K}$						
0.000	0.223	0.224	-0.45	0.000	0.000	0.000
0.013	0.324	0.313	3.40	0.286	0.277	0.009
0.039	0.476	0.468	1.68	0.508	0.510	-0.002
0.081	0.668	0.667	0.15	0.645	0.652	-0.007
0.155	0.885	0.899	-1.58	0.732	0.740	-0.008
0.296	1.097	1.110	-1.19	0.788	0.793	-0.005
0.447	1.217	1.213	0.33	0.816	0.816	0.000
0.671	1.357	1.350	0.52	0.855	0.856	-0.001
0.813	1.456	1.458	-0.14	0.895	0.900	-0.005
1.000	1.575	1.608	-2.10	1.000	1.000	0.000
$T = 210.03 \text{ K}$						
0.000	0.336	0.334	0.60	0.000	0.000	0.000
0.015	0.458	0.447	2.40	0.229	0.243	-0.014
0.041	0.646	0.620	4.02	0.436	0.446	-0.010
0.079	0.858	0.832	3.03	0.584	0.582	0.002
0.155	1.145	1.134	0.96	0.686	0.689	-0.003
0.304	1.457	1.447	0.69	0.754	0.759	-0.005
0.659	1.835	1.809	1.42	0.834	0.836	-0.002
0.811	1.991	1.981	0.50	0.885	0.890	-0.005
1.000	2.163	2.206	-1.99	1.000	1.000	0.000

$$^a \Delta P\% = 100(P_{\text{exp}} - P_{\text{cal}})/P_{\text{exp}} \quad ^b \Delta y = y_{1\text{exp}} - y_{1\text{cal}}$$

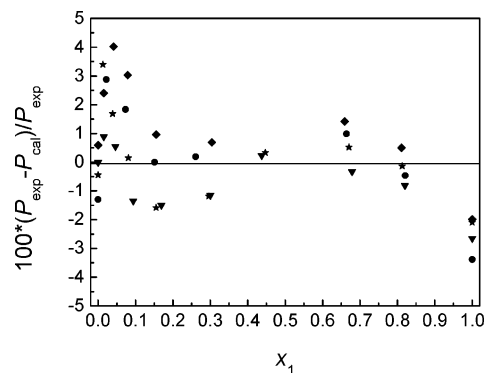

Figure 3. Relative errors of saturation pressure between experimental data and calculated data for {tetrafluoromethane (1) + ethane (2)} at four different temperatures: ●, 179.68 K; ▼, 190.14 K; ★, 200.68 K; ◆, 210.03 K.

the accuracy of the correlation for the vapor pressure of pure tetrafluoromethane, a specific vapor pressure equation for tetrafluoromethane will be necessary to be built in the future.

The mean relative absolute percentage deviations on pressure, $\text{MRD}(P)$, and the mean relative percentage deviations on vapor phase mole fraction, $\text{MRD}(y)$, listed in Table 7, are defined by

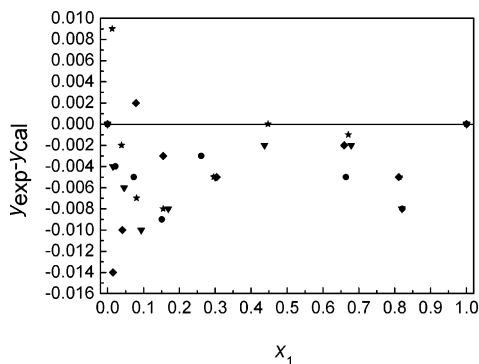

Figure 4. Absolute errors of vapor phase composition between experimental data and calculated data for {tetrafluoromethane (1) + ethane (2)} at four different temperatures: ●, 179.68 K; ▼, 190.14 K; ★, 200.68 K; ◆, 210.03 K.

Table 5. Experimental and Calculated Vapor Pressure for Pure Tetrafluoromethane and Ethane^a

T K	tetrafluoromethane (1)				ethane (2)			
	$P_{1\text{exp}}$ MPa	$P_{1\text{cal}}$ MPa	ΔP_1 MPa	ΔP_1 %	$P_{2\text{exp}}$ MPa	$P_{2\text{cal}}$ MPa	ΔP_2 MPa	ΔP_2 %
179.68	0.681	0.693	-0.012	-1.76	0.077	0.077	0.000	0.00
190.14	1.057	1.072	-0.015	-1.42	0.136	0.137	-0.001	-0.74
200.68	1.574	1.591	-0.017	-1.08	0.223	0.224	-0.001	-0.45
210.03	2.165	2.189	-0.024	-1.11	0.336	0.334	0.002	0.60

$$^a \Delta P = P_{\text{exp}} - P_{\text{cal}}; \Delta P\% = 100(P_{\text{exp}} - P_{\text{cal}})/P_{\text{exp}}$$

Table 6. Experimental Data of the Vapor Pressures for Tetrafluoromethane^a

T/K	$P_{1\text{exp}}$ /MPa	$P_{2\text{exp}}$ /MPa	ΔP /MPa
179.68	2.165	2.166	-0.001
190.14	1.574	1.574	0.000
200.68	1.057	1.058	-0.001
210.03	0.681	0.681	0.000

$$^a \Delta P = P_{1\text{exp}} - P_{2\text{exp}}$$

Table 7. Mean Relative Absolute Deviations of Pressure, MRD(P), and Vapor Phase Compositions, MRD(y), and Bias with PR-HV Model

T/K	bias(P)/%	MRD(P)/%	bias(y)/%	MRD(y)/%
179.68	0.09	1.38	-0.54	0.54
190.14	-0.61	0.94	-0.64	0.64
200.68	0.06	1.15	-0.07	0.70
210.03	1.29	1.73	-1.11	1.18

eq 8:

$$\text{MRD}(S) = (100/N) \sum [(S_{\text{exp}} - S_{\text{cal}})/S_{\text{exp}}] \quad (8)$$

where $S = P$ or y_1 and N was the number of experimental data points.

The bias values listed in Table 7 are defined by eq 9:

$$\text{bias}(S) = (100/N) \sum [(S_{\text{exp}} - S_{\text{cal}})/S_{\text{exp}}] \quad (9)$$

where $S = P$ or y_1 and N was the number of experimental data points. From Table 7, an accurate correlation of the experimental data was found except at 210.03 K. When the temperature

increases near the critical region, adjustment and modeling become very difficult with PR cubic equation of state.

Conclusions

In this paper, the isothermal VLE data at (179.68, 190.14, 200.68, and 210.03) K were measured for {tetrafluoromethane (R14) + ethane (R170)}. The measurements were performed with a recirculation rig. The PR equation with the Huron–Vidal mixing rule was chosen to correlate the experimental data. To get a closed phase envelope curve, the vapor pressures for pure tetrafluoromethane and ethane were compared with the values estimated from REFPROP 7.0. A specific vapor pressure equation for tetrafluoromethane will be needed in the future. At temperatures close to the critical region, it is difficult to get high accuracy of correlation with PR cubic equation of state. The data obtained in this work will be helpful in the accurate design of MJTRs systems.

Literature Cited

- (1) Missimer, D. J. Refrigerant conversion of auto-refrigerating cascade (ARC) systems. *Int. J. Refrig.* **1997**, *20*, 201–207.
- (2) Gong, M. Q.; Luo, E. C.; Zhou, Y.; Liang, J. T.; Zhang, L. Optimum composition calculation for multicomponent cryogenic mixture used in Joule–Thomson refrigerators. *Adv. Cryog. Eng.* **2000**, *45*, 283–290.
- (3) Gong, M. Q.; Wu, J. F.; Luo, E. C.; Qi, Y. F.; Zhou, Y. Study of the single-stage mixed-gases refrigeration cycle for cooling temperature-distributed heat loads. *Int. J. Therm. Sci.* **2004**, *43*, 31–41.
- (4) Luo, E. C.; Gong, M. Q.; Wu, J. F.; Zhou, Y. Properties of gas mixtures and their use in mixed-refrigerant Joule–Thomson refrigerators. *Adv. Cryog. Eng.* **2004**, *49*, 1677–1686.
- (5) Gong, M. Q.; Wu, J. F.; Luo, E. C. Performance of the mixed-gases Joule–Thomson refrigeration cycles for cooling fixed-temperature heat loads. *Cryogenics* **2004**, *44*, 847–857.
- (6) Zhang, Y.; Gong, M. Q.; Zhu, H. B.; Wu, J. F. VLE measurements for a binary system of ethane + hexafluoroethane at a temperature range from 199.64 to 242.93 K. *J. Chem. Eng. Data.* **2005**, *50*, 2074–2076.
- (7) Zhang, Y.; Gong, M. Q.; Zhu, H. B.; Wu, J. F. Vapor–liquid equilibrium measurements and correlations for an azeotropic system of ethane + hexafluoroethane. *Fluid Phase Equilib.* **2006**, *240*, 73–78.
- (8) Calm, J. M. Property, safety, and environmental data for alternative refrigerants. *Proceedings of the Earth Technologies Forum*, Washington DC, 1998.
- (9) Zhang, Y.; Gong, M. Q.; Zhu, H. B.; Liu, J. Y.; Wu, J. F. Development and verification of a new apparatus for low-temperature vapor–liquid equilibria measurement. *Proceedings of the 11th Chinese Engineering Thermophysics Conference*, Beijing, China, 2005 (in Chinese).
- (10) ProII, *User Manual*; Simulation Science Inc.: Brea, CA.
- (11) Peng, D. Y.; Robinson, D. B. A new two-constant equation of state. *Ind. Eng. Chem. Fundam.* **1976**, *15*, 59–64.
- (12) Huron, M. J.; Vidal, J. New mixing rules in simple equations of state for representing vapour–liquid equilibria of strongly non-ideal mixtures. *Fluid Phase Equilib.* **1979**, *3*, 255–271.
- (13) Lemmon, E. W.; McLinden, M. O.; Huber, M. L. *NIST Reference Fluid Thermodynamic and Transport Properties (REFPROP)*, version 7.0; Physical and Chemical Properties Division, National Institute of Standard and Technology: Gaithersburg, MD, 2002.

Received for review December 15, 2005. Accepted April 19, 2006. We thank the National Natural Sciences Foundation of China for the financial support with Grant 50576102.

JE050525C